

SB-30M Extra

PIPELAYER

EPA Tier 3/EU Stage IIIA
STANDARD

ENGINE

	SB-30M Extra
Make and model	Cummins QSB 6.7
Emissions Standard	EPA Tier 3/EU Stage IIIA
Displacement	6.7l (408 in ³)
Bore and stroke	107 x 124 mm (4.21 in x 4.88 in)
Gross Horsepower, SAE J1995	151 kW (203 hp)
Net Horsepower, SAE J1349/ ISO 9249	140 kW (188 hp)
Rated rpm	2000
Max . Torque	945 Nm (700 lb ft)
Air Cleaner	2-stage, dry type, with dash mounted electronic service indicator, precleaner
Cold-Starting Aid	intake- mounted air -inlet grid heater

COOLING

	SB-30M Extra
Type	blowing fan, belt driven
Engine coolant rating	-50 deg C to +40 deg C (-58 deg F to +104 deg F)

HYDRAULICS

	SB-30M Extra
Type	Open-center hydraulic system with fixed-displacement multiple piston and gear pumps
System relief pressure	winch hook and boom 35 MPa (5215 psi); counterweights 12 MPa (1,790 psi)
Control	two lever for winch two lever for counterweight

ELECTRICAL

	SB-30M Extra
Voltage	24 V
Number of batteries	2
Battery capacity	960 CCA
Alternator rating	70 A
Lights	10 total; cab mounted (2F& 2R), 2F grill, 2R fuel tank, 1 boom, 1 winch mounted

OPERATOR STATION

	SB-30M Extra
ROPS	ROPS (ISO 3471 - 2008)
FOPS	FOPS (ISO 3449 - 2005)

OPERATING WEIGHTS

	SB-30M Extra
operating weight, standard equipment, Cab ROPS/FOPS, full fuel tank, and 79-kg [175 lb.] operator	27 580 kg (60 803 lb)

OPTIONAL COMPONENTS

	SB-30M Extra
Track Shoes	
711 mm (28 in)	432 kg (934 lb)

POWERTRAIN

SB-30M Extra

Transmission	Single stage 370 mm (14.6 in) torque converter with a 2.6:1 stall ratio drives to transmission through a double universal joint. Modular, countershaft type power shift transmission, electro-hydraulic control. Preset travel speed selection and auto-downshift.
Steering	Exclusive 2-speed geared steering module provides gradual turns while maintaining full power to both tracks plus conventional clutch-brake performance for tight or pivot turns. Coupled to 3-speed transmission, the 2-speed steering provides 6 speeds forward and 6 reverse. The left hand joystick controls transmission and steering drive for up and down shifting, steering, Hi/Lo selection and LH/ RH gradual geared turn.
Final drives	Double-reduction module type final drives mounted independently of track frames for isolation from shock loads

Total ratio	12.128 to 1		
Travel speeds			
Gear	Range	Forward	Reverse
		km/h (mph)	km/h (mph)
1st	Low	2.9 (1.8)	3.4 (2.1)
	High	3.9 (2.4)	4.6 (2.9)
2nd	Low	5.2 (3.2)	6.1 (3.8)
	High	6.9 (4.3)	8.1 (5.0)
3rd	Low	8.2 (5.1)	9.6 (6.0)
	High	10.8 (6.7)	12.6 (7.8)
Brakes			
Service	Spring applied hydraulically released multi-disc wet brakes. Foot pedal piloted control		
Parking	The steering brakes also act as service and parking brakes. Service brakes are locked automatically when the transmission safety lever is actuated or when the engine is cut off.		

UNDERCARRIAGE

SB-30M Extra

Suspension	Rigid type
Tracks	Large deep-heat-treated, sealed, and lubricated track links and through-hardened, sealed and lubricated rollers for maximum wear resistance
Track Gauge	2170 mm (7 ft 1.5 in)
Track Shoe Width	610 mm (24 in)
Chain	Sealed and lubricated
Shoes, Each Side	43
Track Rollers, Each Side	8
Track Length on Ground	3050 mm (11 ft 10 in)
Ground Contact Area	37000 cm ² (5729 sq in)
Ground Pressure	73.5 kPa (10.7 psi)
Track Pitch	203.2 mm (8 in)
Sprocket segments, each side	1

TRAVEL SPEEDS - LIFTING CAPACITY

SB-30M Extra

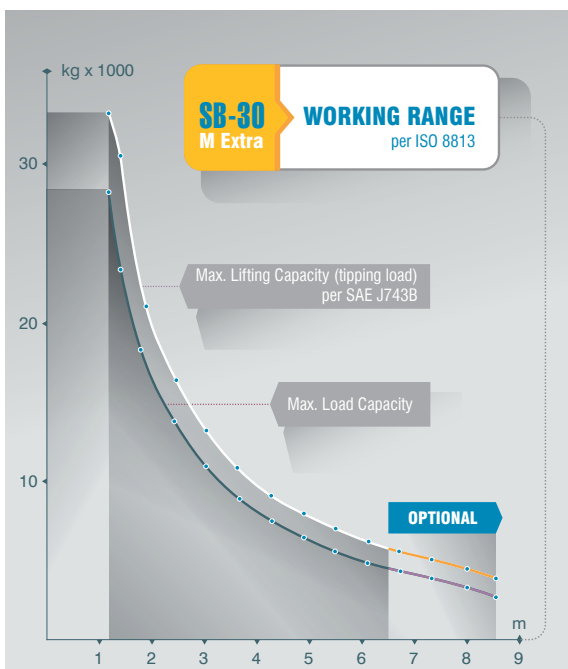

SERVICEABILITY

SB-30M Extra

Refill capacities	
Fuel Tank	316 l (84.3 US gal)
Cooling System	40 l (10.6 US gal)
Engine Oil	23 l (6.14 US gal)
Transmission System	145 l (38.7 US gal)
Final drive, each side	38 l (10.1 US gal)
Hydraulic Reservoir	115 l (30.7 US gal)

MACHINE DIMENSIONS

A Overall Height -ROPS	3520 mm (11 ft 7 in)
B Overall Height -FOPS cab	3420 mm (11 ft 3 in)
C Overhang, min	1220 mm (4 ft)
D Operating length	4400 mm (14 ft 5 in)
E Width of tractor (counterweight extended)	4650 mm (15 ft 3 in)
H Hook height max w/std boom	5550 mm (18 ft 2.5 in)
N Length track on ground	3050 mm (10 ft)
O Width of tractor counterweight/boom removed	3210 mm (10 ft 6 in)
P Track gauge	2170 mm (7 ft 1.5 in)

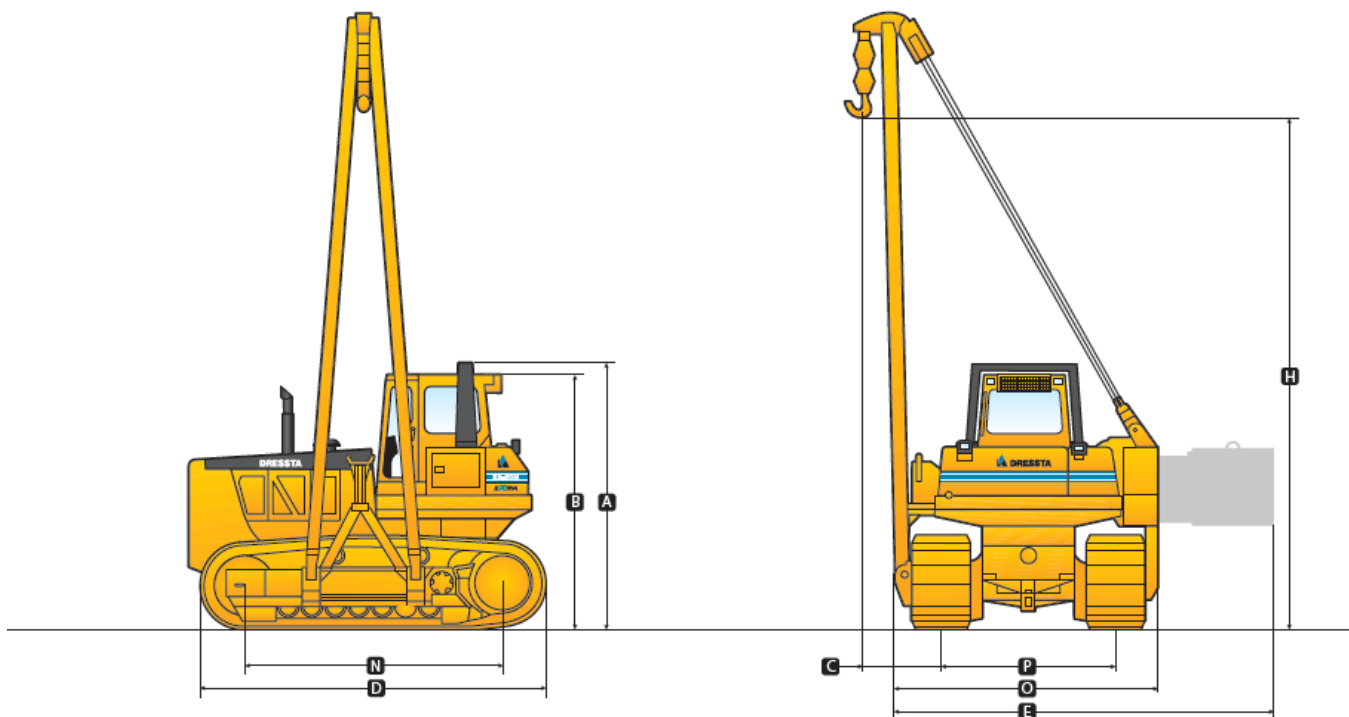

PIPELAYING EQUIPMENT

Boom length std/optional	6,500 mm / 8,500 mm (21 ft 4 in / 27 ft 9 in)
Counterweights	adjustable hydraulically controlled 2 pcs / 4380kg
Live power	continous power to pipelayer winches independent of torque converter
Winch transmision	operated independently or simultaneously, planetary hydraulic winches, 2 speed for raising, 2 speed for lowering
Drums diameter (hook &boom)	340 mm (13.4 in) / 340 mm (13.4 in)
Wire rope length (inside flanges) hook/boom	55 m (180 ft 5 in) / 45 m (147 ft 7 in)
Wire rope diameter	19 mm (3/4 in)
Hook speed:	
raise 1st	11.7 m/min (38.4 ft/min)
raise 2nd	21.3 m/min (70 ft/min)
lower 1st	11.7 m/min (38.4 ft/min)
lower 2nd	27.1 m/min (88.9 ft/min)
max lifting capacity per SAE 743B	33 t (72752 lb)

STANDARD EQUIPMENT SB-30M Extra

ENGINE

Engine, Cummins QSB6.7, Tier 3/ EU Stage IIIA, emission certified, turbocharged, direct start, direct injection, 140 kW (188 fwhp)

Air cleaner, dry type w/exhaust aspirated primary and safety elements and service indicator

Antifreeze, -37°C (-34°F)

Cooling module; includes radiator, transmission oil cooler, hydraulic oil cooler, charge air cooler; isolation mounted

Exhaust pipe extension

Fan, blower

Filter, oil, spin -on type

Filters, drive train system, hydraulic system, engine fuel system

Muffler, under engine hood, insulated

Strainers, fuel and hydraulic tanks

Water separator, fuel system

DRIVETRAIN

Torque converter, single stage

Transmission, power shift, 3 speeds forward, 3 reverse combined with 2 speed steering provides 6 speeds forward, 6 reverse

Steering, planetary type, 2 speed, left hand single lever control (joystick)

Brakes, wet, multiple disc, closed type, spring applied hydraulically released

Decelerator - right foot pedal, and brake - center foot pedal

OPERATOR'S ENVIRONMENT

Cab with sound suppression, air recirculation system, 1 side (LH) light, 4 wipers w/washers, dome light, inside mirror, roof window and emergency hatch (approved according to FOPS - SAE J231)

Seat, deluxe, air suspension type, fabric cover, adjustable with arm rests

Seat belt (SAE J386) - 3" wide, retractable

Sun visor for front cab window

Tools compartment

BOOM

Lifting capacity - 33 100 kg (72,972 lb) @ load overhang of 1220 mm (4') and cwt max extended (per SAE J743b)

Boom, welded type, box-section structure, 'A' shape frame, length 6500 mm (21'4")

Boom kickout, uppermost position

Brake, hook lowering, auxiliary

Emergency hook lowering system

Load capacity indicator, mechanical, on boom frame

INSTRUMENTATION

Gauges: fuel level, engine coolant temperature, engine oil pressure, torque converter oil temp., voltmeter, hourmeter, brake lock, emergency hook lowering, joystick control display

Warning lights: air cleaner filter, transmission oil filter, hydraulic oil filter, transmission/clutch oil low pressure, counterweights extended, hook top limit position, boom top limit position

Audible & visual warning system: low engine coolant level, low engine oil pressure, coolant high temperature, hydraulic oil high temperature

ELECTRICAL

Alarm, back-up

Alternator 70 A

Dual batteries 12 V, 960 CCA, maintenance free

Horn, electric

Light, boom

Lights w/guards, 2 front, 2 rear, tractor mounted

Starting, 24 V

Starting aid - air grid heater

Receptacle, starting/charging

GUARDS

Guards; crankcase - hinged with front pull hook, fan, transmission and track roller

Engine hood, sloped, perforated type

Engine side doors, hinged, perforated type

Final drive seal guard

Radiator guard door, two-piece, louvered, hinged

UNDERCARRIAGE

Track adjusters, hydraulic

Track chain, sealed and lubricated (LTS) with split master link, 43 links

Track chain guides, integral

Track frames, 8 roller, 2160 mm (85") gauge, non-oscillating type, lifespan lubricated rollers & idlers

Track shoes, 610 mm (24") severe service

OTHER STANDARD EQUIPMENT

Bumper, front

Counterweights, adjustable, hydraulically controlled, 2-block and 2-counterweight frames; total weight extendable - 5360 kg (11817 lb)

Drawbar, fixed

Ecological drains for engine oil, radiator coolant and hydraulic oil

Manuals, parts and operator's

Rear access platform

Winch transmission (two separate winches for hook and boom with hydrostatic drive system and planetary transmission)

OPTIONAL EQUIPMENT SB-30M Extra

WORKING ATTACHMENTS

Boom, welded type, box section structure, 'A' shape frame length 6500 mm (21'4") with electronic load limit indicator

Boom, welded type, box section structure, 'A' shape frame length 8500 mm (27'9") with or without electronic load limit indicator

Hook pulley block limit switch, uppermost position

TRACK SHOES

711 mm (28") shoes, severe service

OPERATOR'S ENVIRONMENT

Air conditioner/heater/pressurizer/defroster, underseat mounted, behind roof mounted A/C condenser

Heater/pressurizer/defroster

ROPS, for use with standard Cab

For use with cab:

- AM/FM CD radio
- Lights for cab, 2 rear
- Mirrors, 2 pcs, exterior, cab mounted
- Sun visors (2), additional, for side door windows

GUARDS

Transmission and engine crankcase guards, severe service

Crankcase guard with front pull hook

Solid hood and perforated side doors

ADDITIONAL OPTIONS

Batteries, cold start, (2) 12 V, 960 CCA

Inspection lamp, 24 V, portable, with 6 m (20') cable

Light, winch

Starting/charging receptacle plug assembly with cable (required to jump start or charge batteries)

Vandalism protection

Maintenance tool kit, 17 items in a metal box

1000 h maintenance package (filters)

1500 h maintenance package (filters)

2000 h maintenance package (filters)

SFR

Export packing, drive-on / drive-off

Beacon light, rotating

Coolant heater (Eberspacher), with additional fuel tank

Fuel Filtration System Fleetguard

At Dressta we take pride in innovating to help our customers to achieve more in the jobs they do.

Our dedicated team of application engineers can customize designs, modify standard equipment and adapt attachments for peak performance in specific application tasks, improving productivity and bottom line results.

Do you have a Special Feature Request? See how Dressta can help you achieve more in the jobs you do.

Specifications may change from time to time and this brochure may not reflect the latest specifications. Photographs in this brochure may not reflect market configuration. Please consult your dealer to confirm specifications and configurations.



Dressta encourages safe worksites.

Please consult operator's manual before use of any Dressta equipment.



info@dressta.com
www.dressta.com

DR-SP-SB30M-T3-A4-30062017-ENG